

4:1 SAND CEMENT BED 50mm HIGH REQUIRED
 4:1 SAND CEMENT BACKFILL MIN 300mm HIGH FOR STANDARD INSTALLATION.
 -FOR DEEPER INSTALLATIONS REFER TO INSTRUCTIONS
 -FOR WATER CHARGED GROUND REFER TO YOUR PROJECT STRUCTURAL ENGINEER.

SECTION 'AA'
 SCALE 1:25

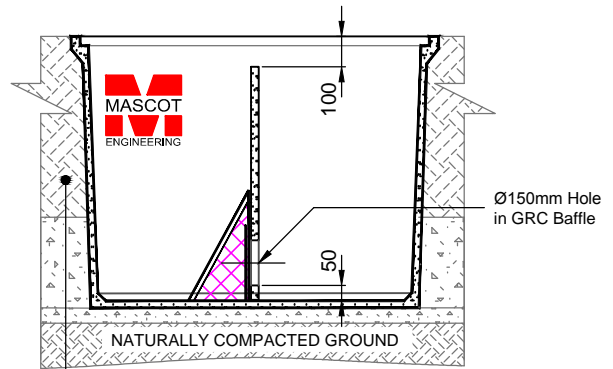

CONTRACTOR TO ALLOW FOR SUPPLY & INSTALL OF CLEAN BACKFILL MATERIAL

SECTION 'BB'
 SCALE 1:25

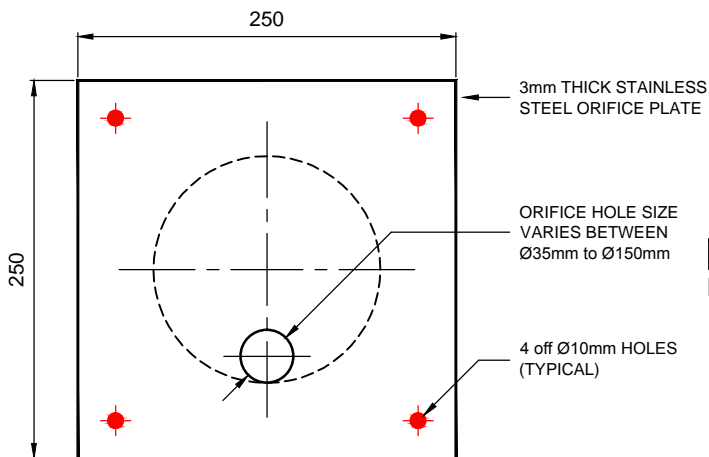

STAINLESS STEEL ORIFICE PLATE DETAIL
 SCALE 1:5

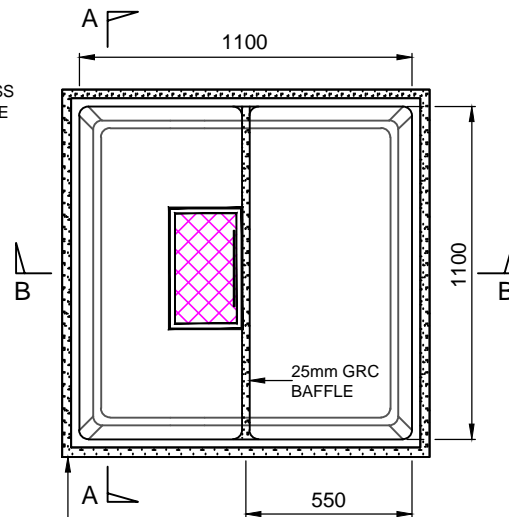

OPEN TANK PLAN VIEW
 SCALE 1:25

CONTRACTOR TO ALLOW FOR SUPPLY & INSTALL OF A VICTORIAN DETENTION TANK MADE BY MASCOT ENGINEERING
 MODEL: VDT690
 1200mm X 1200mm X 900mm high
 TOTAL WEIGHT OF PRODUCT: 290kg

PRODUCT NOTE:

1. TESTED AND APPROVED FOR INSTALLATIONS UP TO 5000mm DEEP.
2. PIT RISERS AVAILABLE.
3. LARGE RANGE OF CONCRETE SURROUNDS AND GRATES AND COVERS TO SUIT ALL LOAD RATINGS.
4. MPA RATING FOR GRC - 60 mpa @ 28 DAYS.
5. AVAILABLE EXTRAS:-STEP IRONS
6. CUSTOM FEATURES TO THIS TANK ARE AVAILABLE UPON REQUEST.
7. INSTALLATION INSTRUCTIONS MUST BE FOLLOWED.
8. SOME COVERS WILL ADD TO OVERALL DEPTH.

SPECIFICATION

Glass Reinforced Concrete Settling Tank must be free of steel reinforcement to prevent corrosion.
 Detention Tank to be Mascot Engineering GRC model number VDT 690 complete with 304SS orifice plate withmm diameter opening, removable screen and GMS Cover/Grate to suit Class to AS3996.
 Products to be installed as per the manufacturers installation instructions

AUTHORISED FOR USE IN VICTORIA

© Copyright

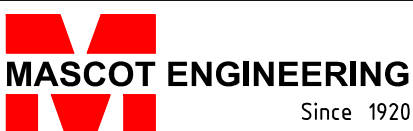

PRODUCT DESCRIPTION:

VIC DETENTION TANK

ph: 1300 885 295
 fax: 1300 885 296
 email: sales@mascoteng.com.au
 www.mascotengineering.com.au

SCALE:

1:25

REVISION:

A

DRAWING NO:

TW.VIC.VDT.001