

SIDE SECTION
SCALE 1:25

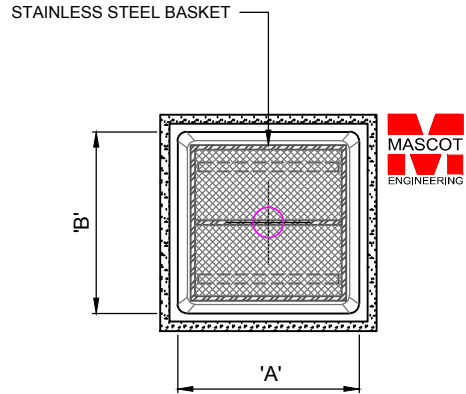

OPEN TANK PLAN VIEW
SCALE 1:25

PRODUCT NOTE:

1. MPa RATING FOR GRC - 60 MPa @ 28 DAYS.
2. OTHER PVC-U PIPE SIZES AVAILABLE UPON REQUEST
3. INTERNALLY COATED WITH ACID RESISTANT TAR EPOXY PAINT.

PRODUCT CODE	A	B	C	MASS (KG)
FBA4	450	450	525	39
FBA6	600	600	525	65

SPECIFICATION

Glass Reinforced Concrete Floor Basket Arrestor free of steel reinforcement to prevent corrosion.
 Floor Basket Arrestor to be Mascot Engineering GRC, model number....., complete with Channelling Tray Grate to suit Class load rating to AS3996.
 Products to be installed as per the manufacturers installation instructions

© Copyright

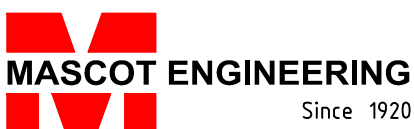

PRODUCT DESCRIPTION:
FLOOR BASKET ARRESTOR

ph: 1300 885 295
 fax: 1300 885 296
 email: sales@mascoteng.com.au
 www.mascotengineering.com.au

SCALE: 1:25	REVISION: A
DRAWING NO: TW.FBA.001	